

# PATTERSON LAMPS

## TYPE A.1



**FOR THE MINER**  
Flame Safety Lamp type A1  
Safety Lamps Approval B1128

### TYPE A.1

Electrically lighted and magnetically unlocked

**CONSTRUCTION :** The burner is provided with a male screw ring for attachment to the middle ring. The male screw ring is provided with twenty-four vertical air-inlet holes of total area of 1.18 square inches. Improved burning is secured by an inner chimney of steel which secures proper circulation of air to the flame. The lamp cannot be assembled unless both gauzes are in correct position. The construction is simple and robust ensuring low cost of upkeep.

**LOCKING :** Entirely enclosed and absolutely impregnable. The lock bolt can only be withdrawn by means of a powerful electro-magnet in the lamp-room. Besides locking the oil vessel, the bonnet, gauzes and glass are automatically locked in position.

**LIGHTING :** Correct and certain contact on the Lighting Apparatus is assured both in the lamp room and in the underground lighters. The electric ignition device is fitted to the side of the lamp and is easily kept clean. This lamp is now made either with or without electric ignition, as desired.

**FILLING :** A spring-loaded oil filling valve is fitted in the top of the oil vessel for filling by a machine to economise on labour in the lamproom.

**LIGHT :** The lamp is fitted with a flat burner and gives over 1 C.P.

Weight—3 lbs. 5ozs.

Height to top of bonnet—10½ inches

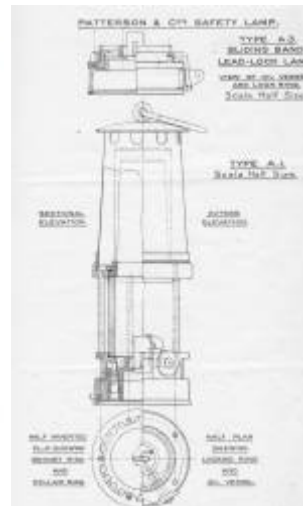

Little story about the Paterson A1 from John Harvey:

„Some things money cannot buy Just a very plain old Patterson A 1. BUT I was brought up in the 1940,s in Durham a mining family, two pitmen Tommy and Joe both on different shifts, So tin bath in front of the fire twice daily, and pit clothes hanging in front of the fire to dry ready for the next shift. I can still smell them. Well both Tommy and Joe had allotments with old greenhouses, and Tommy “borrowed” two old lamps from The Rainton Meadows. In about 1940. The purpose of theses was to put in the greenhouse lit to keep out the frost. Well Tommy had worked in The Meadows all his life apart from a short five year holiday in The Royal Artillery WW1. So after his death I recovered both lamps. The Patterson B7 I gave to my daughter, the A1 stays by my fireplace. Money could not buy it.“

## TYPE A.3



## TYPE B.7

### TYPE B.7

Electrically lighted and magnetically unlocked.

**CONSTRUCTION:** The bonnet is securely fastened to the middle ring. The middle ring is provided with vertical air inlet holes having a total area of 1.5 square inches. Satisfactory burning is ensured by a short chimney of steel which directs the flow of air within the lamp. The burner is encased in porcelain giving a clear flame with low oil consumption. The bottom ring is provided with a female screw thread which engages a glass sealing ring and the oil vessel respectively. There are only four pillars between the middle and bottom rings giving the minimum amount of obstruction between the flame and the observer. The lamp cannot be assembled unless both gauges are in their correct position.

This construction represents the maximum of efficiency obtainable with the ordinary Marsaut type of lamp.

**LOCKING:** Entirely enclosed and absolutely impregnable. The lamp can be unlocked only on a powerful electro-magnet in the lamproom.

**LIGHTING:** The Lighting Apparatus is provided with a special locating device which ensures proper contact for lighting.

**FILLING:** A spring loaded oil filling valve is fitted to the top of the oil vessel.

**LIGHT:** The lamp is fitted with a flat burner and the flame is very suitable for gas testing purposes.

Weight—3 lbs. 6 ozs.  
Height to top of bonnet—10½ inches

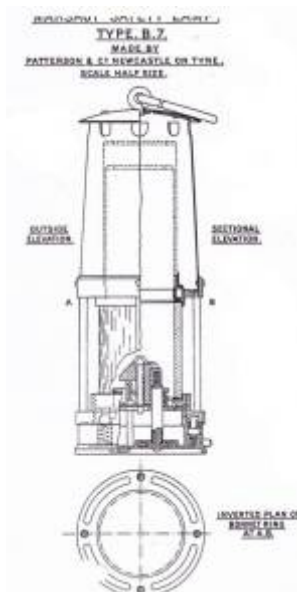

# TYPE M. IG.



## PATTERSON'S

### Type M. IG. GAS DETECTING LAMP

Approved by the Ministry of Fuel & Power  
for use by

- DEPUTIES
- FIREMEN
- SHOTFIRERS
- and OTHER OFFICIALS

(SCHEDULE 'B' - CLASS 'B')

Complying with the Coal Mines S.B. & O.  
of 1935. Nos. 1406, 1407 and 1410

# TYPE E.1



BY GUARDIAN. January 4, 1929

**Our Patent Approved TYPE E.1,  
OIL SAFETY LAMP.**

SINGLE GLASS ONLY.		LOW UPKEEP COST.
2'0 C.P.		WEIGHT 3½ lbs.
<b>PERFECT</b>		<b>SAFETY</b>

SUPERIOR TO ELECTRIC OR ANY OTHER OIL LAMPS.  
(SEE SPECIAL PATENT AND SPECIFICATIONS.)  
Unmuffled Run, Detachable, Simple Construction,  
Stands Unhindered during any TIPPING without Interruption,  
Smoking and Overheating Effectually Prevented,  
Electric Ignition, Magneto or Lead Lamps.

**COMPLETE LAMPROOM EQUIPMENTS.**

**PATTERSON & CO.,**  
Trafalgar St. Works,  
NEWCASTLE-ON-TYNE.

Patented "Lamp Room" in Great Britain. ESTABLISHED 1862.



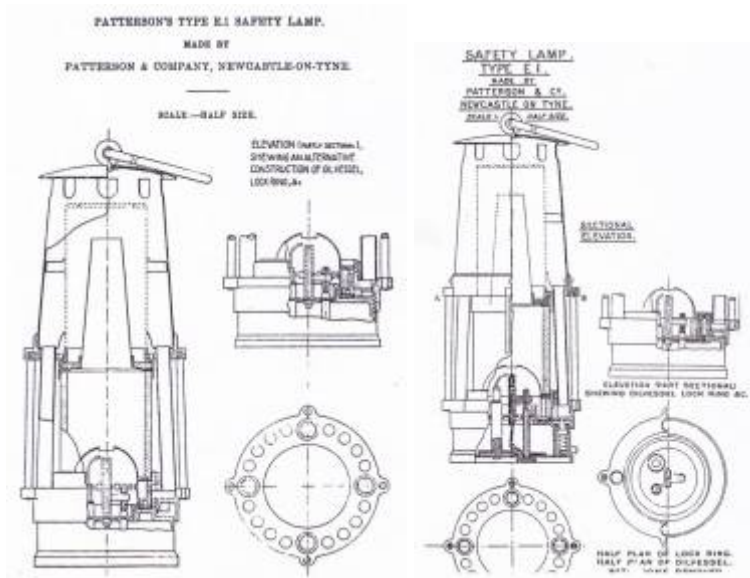

## TYPE GTL9



## TYPE TVI





## TYPE H.C.P.



## TYPE H.C.P.9



## Patent Baxendale

Es handelt sich um eine typische Baxendale-Lampe, die mit einem Smith-Mantel ausgestattet ist. Baxendale hat nicht so viele verschiedene Modelle gebaut. Obwohl diese Lampe sehr beliebt war, ist der Smith-Mantel nicht so häufig zu finden.



Gary Chedgy: It's a typical Patterson patent Baxendale lamp but featuring Smith's patent bonnet. Baxendale didn't make that many different lamps but this was there most popular it's just you don't often see it with the Smith's bonnet.

## Catalog

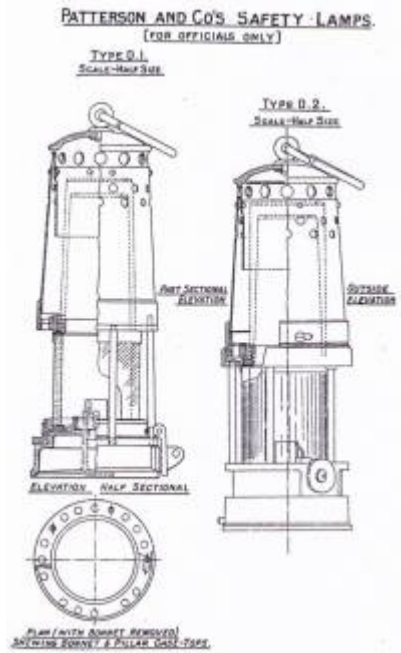
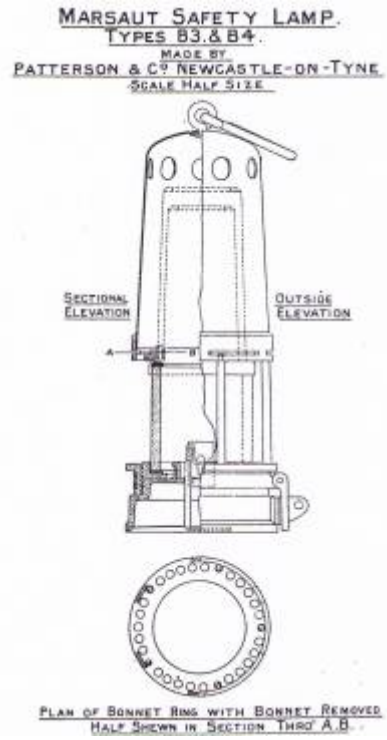
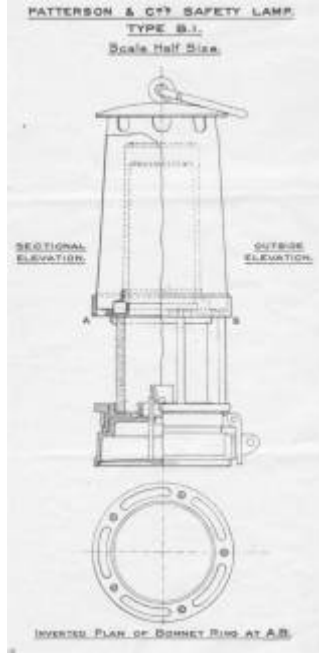
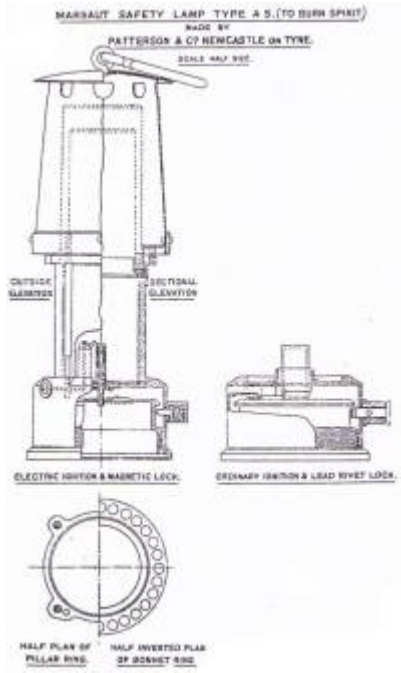

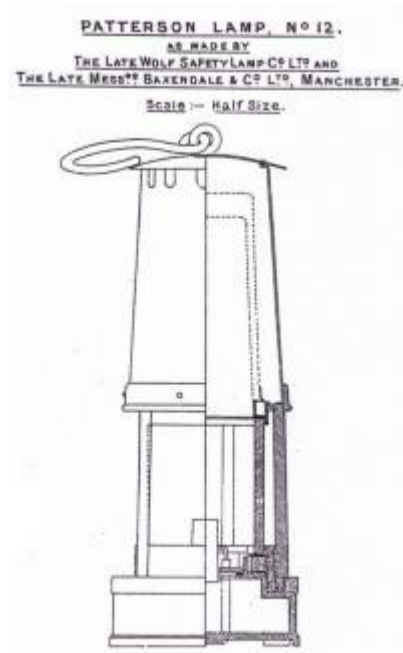

[Back to Mining lamps UK](#)

From:  
<https://www.karl-heupel.de/dokuwiki/> - **KarlHeupel**

Permanent link:  
<https://www.karl-heupel.de/dokuwiki/doku.php?id=grubenlampen:patterson&rev=1585218605>

Last update: **2020/03/26 11:30**

